

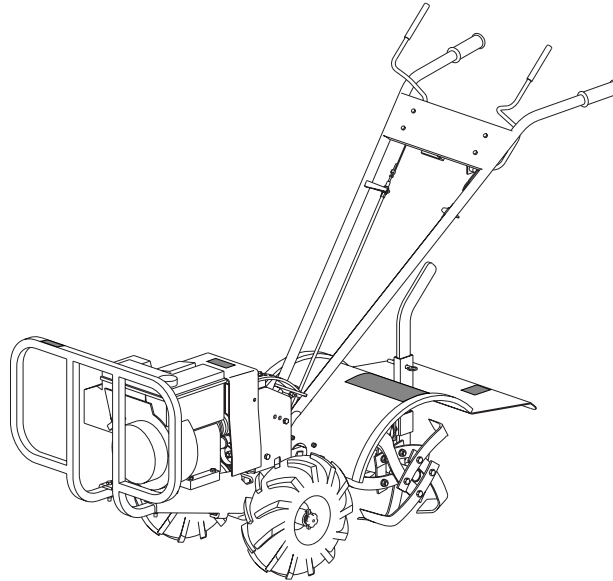

OPERATOR'S MANUAL



Rear Tine Tiller

6HP Rear Tine Tiller

Mfg. No.	Description
1694161	6016RT, 6HP Rear Tine Tiller
1694908	6016RT, 6HP Rear Tine Tiller
7800052	6016RT, 6HP Rear Tine Tiller

7HP Rear Tine Tiller

Mfg. No.	Description
1694162	7016RT, 7HP Rear Tine Tiller
1694909	7016RT, 7HP Rear Tine Tiller
7800053	7016RT, 7HP Rear Tine Tiller

Table Of Contents

MODEL IDENTIFICATION	1	OPERATION	11
SAFETY RULES	2	Pre-Start Inspection	11
Owner's Responsibility	2	Start-up	11
General	2	Shutting Down	12
Preparation	2	Tilling	12
Operation	3	TIPS	13
Maintenance & Storage	3	Tilling Tips	13
Safety Decals	4	Cultivating Tips	13
FEATURES	5	NORMAL CARE	14
CONTROLS	6	Schedule	14
Drive Safety Control Levers	6	Servicing The Rototiller	15
Reverse Handle	6	STORAGE	19
Engine Controls	7	Storage	19
ADJUSTMENTS	8	TROUBLESHOOTING AND REPAIR	20
Wheel Lockpins	8	Troubleshooting Guide	20
Wheel Lockouts	8	SPECIFICATIONS	22
Handlebar Adjustments	9	Features	22
Depth Regulator Lever	10	TECHNICAL MANUALS	22
Belt Tension Adjustment	10	NOTES	23

MODEL IDENTIFICATION

Record your model number, manufacturer number and serial number in the space provided for easy reference. The model and manufacturer numbers can be found on the unit I.D. plate located on the unit's left engine mount. Refer to the Engine Owner's Manual for location of engine serial number.

If you have a service problem requiring special assistance, contact a local dealer for help.

ROTOTILLER REFERENCE DATA	
Model Description/Number	
M/N (Manufacturer's Number)	S/N (Serial Number)
Dealer Name	Date Purchased
ENGINE REFERENCE DATA	
Engine Make/Model	Engine ID/Serial Number

WARNING

You must read, understand and comply with all safety and operating instructions in this manual before attempting to setup and operate your rototiller.

Failure to comply with all safety and operating instructions can result in loss of machine control, serious personal injury to you and/or bystanders, and risk of equipment and property damage. The triangle in the text signifies important cautions or warnings which must be followed.

WARNING

Engine exhaust from this product contains chemicals known, in certain quantities, to cause cancer, birth defects, or other reproductive harm.

Safety Rules

OWNER'S RESPONSIBILITY

Safe and effective use of the rototiller is the owner's responsibility.

1. Read and follow all safety instructions.
2. Maintain the tiller according to directions and schedule included.
3. Ensure that anyone who uses the tiller is familiar with all controls and safety precautions.

GENERAL

 The Safety Alert symbol shown here is used to alert you to important safety information that must be read, fully understood, and followed at **all** times when handling, transporting, operating, servicing, or storing your rototiller unit.

Each safety alert symbol is followed by a "signal word" that advised you of the relative intensity, or level, of the hazard the safety alert instructions pertain to.

The following list of signal words is being provided to help you understand the intensity levels associated with each signal word used in this manual.

DANGER

The signal word "DANGER" is used when a serious injury or fatality will result if the safety instructions that follow this signal word are not obeyed.

WARNING

The signal word "WARNING" is used when a serious injury or fatality could result if the safety instructions that follow this signal word are not obeyed.

CAUTION

The signal word "CAUTION" is used when personal injury, or property or equipment damage could result if the safety instructions that follow this signal word are not obeyed.

- **CAREFULLY READ THIS MANUAL AND FOLLOW ALL INSTRUCTIONS.**
- Be familiar with all controls before operating the tiller. Your tiller is equipped with a safety device that enables you to stop the wheels and tines quickly in an emergency. Learn how the drive safety control levers work and how to control the tiller at all times.
- Never allow children to operate the tiller. Keep small children away from the area being tilled. Do not allow adults to operate the tiller without proper instruction.



The right and left sides of your rototiller are determined from the operating position as you face the direction of forward travel.

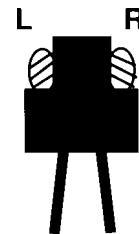

PREPARATION

- Dress appropriately when operating the tiller. Always wear sturdy footwear. Never wear sandals, sneakers, or open shoes, and never operate the tiller with bare feet. Do not wear loose clothing that might get caught in moving parts.
- Carefully inspect the area to be tilled, and remove all foreign objects. Do not till above underground water lines, gas lines, electric cables, or pipes. Do not operate the tiller in soil with large rocks and foreign objects which can damage the equipment.
- Disengage all clutches and shift into neutral before starting the engine.
- Handle fuel with care; it is highly flammable.
 - a. Use an approved fuel container.
 - b. Never add fuel to a running engine or hot engine.
 - c. Fill fuel tank outdoors with extreme care. Never fill fuel tank indoors.
 - d. Replace gasoline cap securely and clean up spilled fuel before restarting.
- Never attempt to make any adjustments while the engine is running.



Engine is shipped from factory without oil. You must add engine oil before starting engine.

OPERATION

- Never operate the tiller without guards, covers, and hoods in place.
- Never start the engine or operate the tiller with the wheels in the free-wheel position. Make sure the wheel lockouts or lockpins are engaged through wheel hubs and wheel axle. The wheels act as a brake to keep the tiller at a controlled speed. Disengage wheels to permit free-wheeling only when engine is stopped.
- Keep hands, feet, and clothing away from rotating parts. Keep clear of tiller tines at all times.
- Tines and wheels rotate when tiller is engaged in **forward** or **reverse**-- in **forward**, tines and wheels rotate when the drive safety control levers are pulled down; in **reverse**, wheels and tines rotate when the reverse handle is pulled back towards the operator. Releasing the drive safety control levers to **neutral** stops the wheels and tines.
- Be extremely cautious when operating in **reverse**. Take extra care to avoid slipping or falling, and to keep feet clear of tines.
- Exercise extreme caution when operating on or crossing gravel drives, walks, or roads. Stay alert for hidden hazards or traffic.
- After striking a foreign object, stop the engine, remove the wire from the spark plug, thoroughly inspect the tiller for any damage, and repair the damage before restarting and operating the tiller.
- If vegetation clogs the tines, raise the handlebars to elevate the tines, and run the tiller in **reverse**. If this does not clean clogged vegetation from the tines, **STOP THE ENGINE AND DISCONNECT THE SPARK PLUG WIRE** before removing vegetation by hand.
- Engine muffler will be hot from operation. Do not touch it with bare skin or a severe burn may result.
- If the unit should start to vibrate abnormally, stop the engine and check immediately for the cause. Vibration is generally a warning of trouble.
- Do not run the engine indoors; exhaust fumes are dangerous.
- Do not overload the machine capacity by attempting to till too deep at too fast a rate.
- Never operate the machine at high transport speeds on slippery surfaces. Look behind and use care when backing.

- Never allow bystanders near the unit.
- Use only attachments and accessories approved by the manufacturer of the tiller.
- Never operate the tiller without good visibility or light.
- Be careful when tilling in hard ground. The tines may catch in the ground and propel the tiller forward. If this occurs, let go of the handlebars and do not restrain the machine.
- Take all possible precautions when leaving the machine unattended. Disengage all controls levers, stop the engine, wait for all moving parts to stop, and make certain guards and shields are in place.
- When leaving the operating position for any reason:
 - shut off the engine.
 - wait for all moving parts to stop.

MAINTENANCE AND STORAGE

- Keep machine, attachments, and accessories in safe working condition.
- Check shear bolts, engine mounting bolts, and other bolts at frequent intervals for proper tightness to be sure the equipment is in safe working condition.
- To prevent accidental starting, always disconnect and secure the spark plug wire from the spark plug before performing tiller maintenance.
- Never run the engine indoors. Exhaust fumes are deadly.
- Always allow muffler to cool before filling fuel tank.
- Never store equipment with gasoline in the tank inside a closed building where fumes may reach an open flame or spark. Allow the engine to cool before storing in any building.
- Always refer to the operator's guide instructions for important details if the tiller is to be stored for an extended period.

Safety Rules

SAFETY DECALS

This rototiller unit has been designed and manufactured to provide you with the safety and reliability you would expect from an industry leader in outdoor power equipment manufacturing.

Although reading this manual and the safety instructions it contains will provide you with the necessary basic knowledge to operate this equipment safely and effectively, we have placed several safety labels on the tiller to remind you of this important information while you are operating the unit.

These important safety labels are illustrated below, and are shown here to help familiarize you with the location and content of the safety messages you will see as you perform normal tilling operations. Please review these labels now, and if you have any questions regarding their meaning or how to comply with these instructions, reread the complete safety instruction text on the preceding pages, or contact your local dealer.

Should any of these labels become unreadable because of being worn, faded, or otherwise damaged during the use of your tiller, please use the part number information provided to order a replacement label from your local authorized dealer.

These labels are easily applied, and will act as a constant visual reminder to you, and others who may use the equipment, to follow the safety instructions necessary for safe, effective operation of your rototiller.

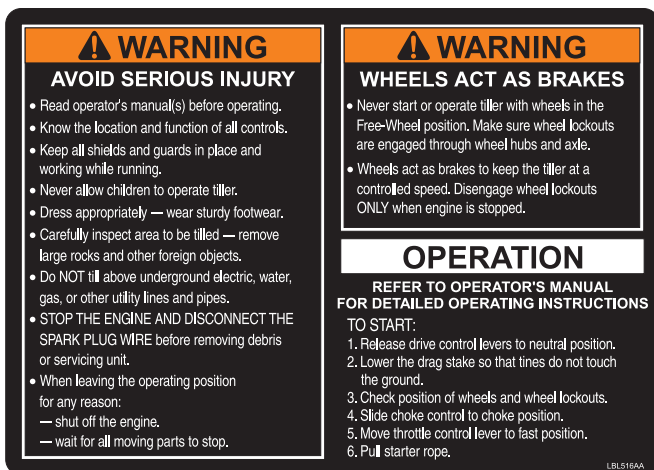

Part No. 1716747
OPERATING INSTRUCTIONS / Hood Decal



Part No. 1716839
FREE HAND / Bumper Guard Decal

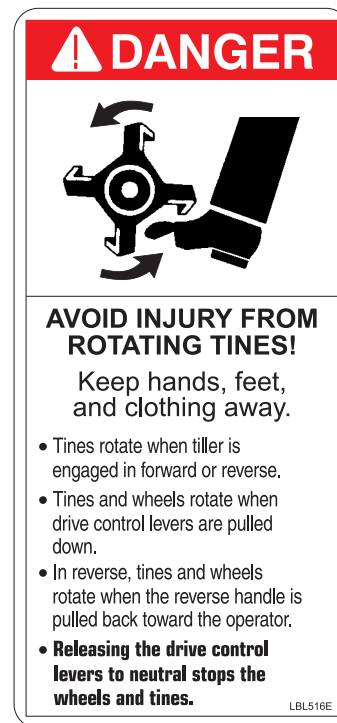

Part No. 1716840
TINES DANGER / Hood Flap Decal



Part No. 1716800
WARNING / Belt Cover Decal

MODEL 7016RT*

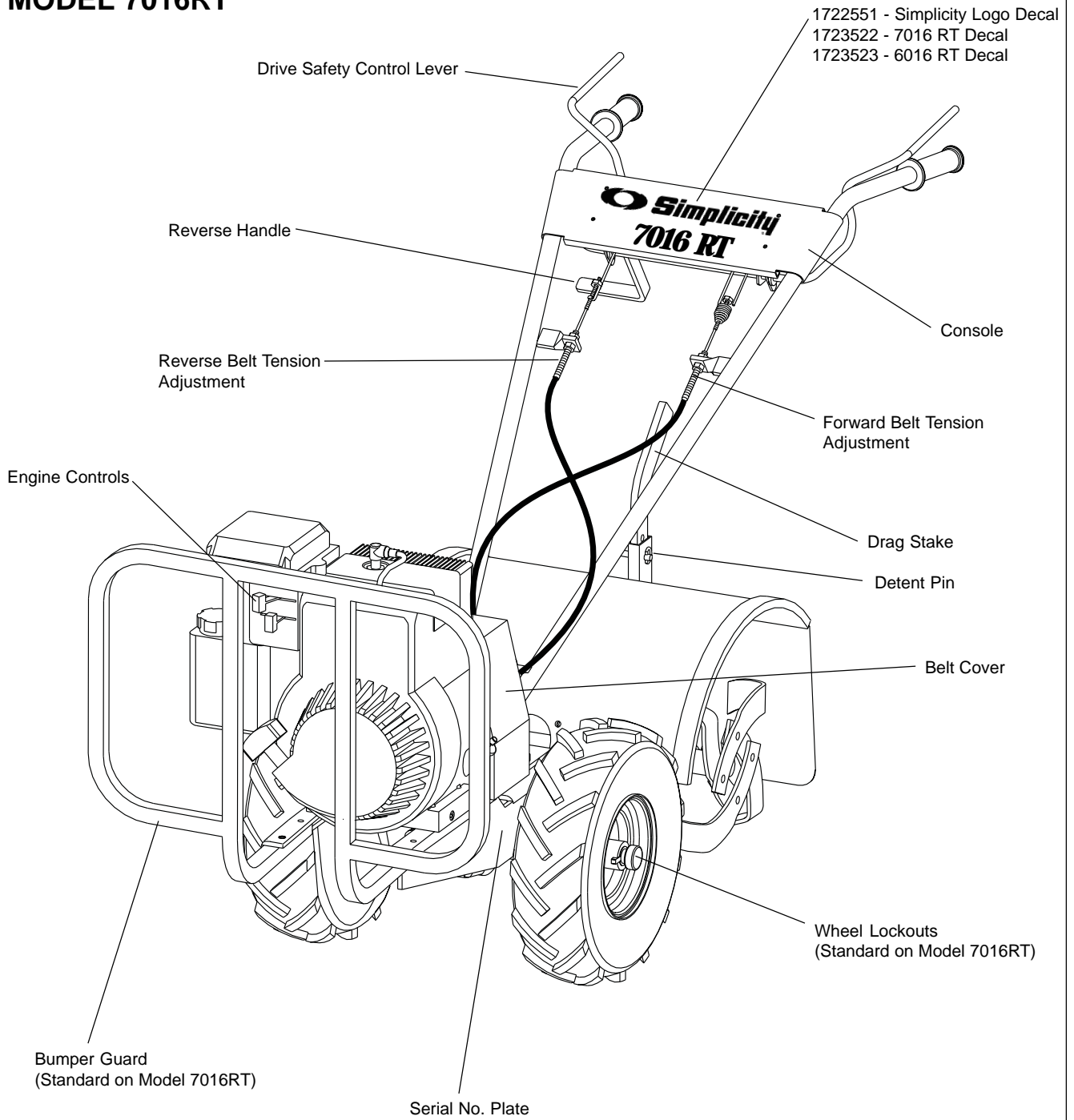

*** Hiller-Furrower Attachment
is standard on Model 7016RT**

Controls

DRIVE SAFETY CONTROL LEVERS

Engage wheels and tines into forward, releasing returns machine to neutral.

Pulling down on drive safety control levers engages the wheels and tines. Releasing drive safety control levers disengages the wheels and brings the tiller to a complete stop. It is now in the neutral position.

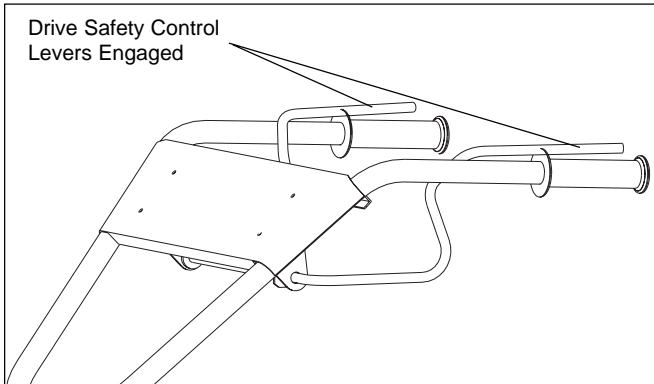

⚠ CAUTION

This information is provided here only to introduce the controls. **DO NOT START THE ENGINE AT THIS TIME.** Starting and operating instructions are given on page 11. Please read this section and all operating and safety instructions before starting your tiller.

⚠ WARNING

ENGINE SHOULD BE OFF BEFORE ADJUSTING ANY CONTROLS.

⚠ CAUTION

- ❖ As a safety precaution, the drive safety control levers will not lock in the forward position.
- ❖ To stop the wheels and tines at any time release the drive safety control levers.

REVERSE HANDLE

Engages wheels and tines in reverse.

Pulling reverse handle back towards operator reverses tiller.

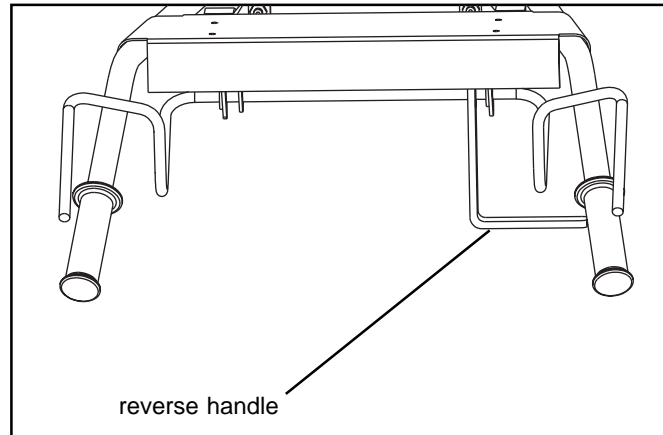

⚠ WARNING

Extreme caution should be used when operating rototiller in the reverse direction.

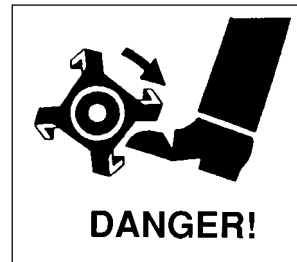

⚠ CAUTION

- ❖ As a safety precaution, the reverse handle will not lock in reverse.
- ❖ To stop the wheels and tines at any time, release the reverse handle.
- ❖ Do not operate both the reverse handle and drive safety control levers at the same time.

ENGINE CONTROLS

Your new rototiller has been designed for both ease of use and lasting reliability, and features a simplified control system that requires just two operating controls.

These two operating controls, the **Choke** and the **Throttle**, are conveniently located on the tiller engine where they can be easily adjusted to start and run the unit under a variety of operating conditions.

Throttle

The throttle controls engine speed, and allows you to conserve fuel when idling, or to run the unit at maximum speed for optimal tilling performance.

Choke

Put choke control in choke position if engine is cold. A warm engine requires less choking than a cold engine.

Refer to your engine manual for further information.

Model 7016RT & 6016RT

1. Spark plug wire
2. Air cleaner
3. Choke
4. Carburetor
5. Fuel shut-off valve (if equipped)
6. Rope handle
7. Finger guard
8. Stop switch (if equipped)
9. Fuel fill
10. Fuel tank
11. Oil fill/Dipstick (if equipped)
12. Blower housing
13. Oil drain plug
14. Oil fill cap
15. Engine Id plate
16. Muffler

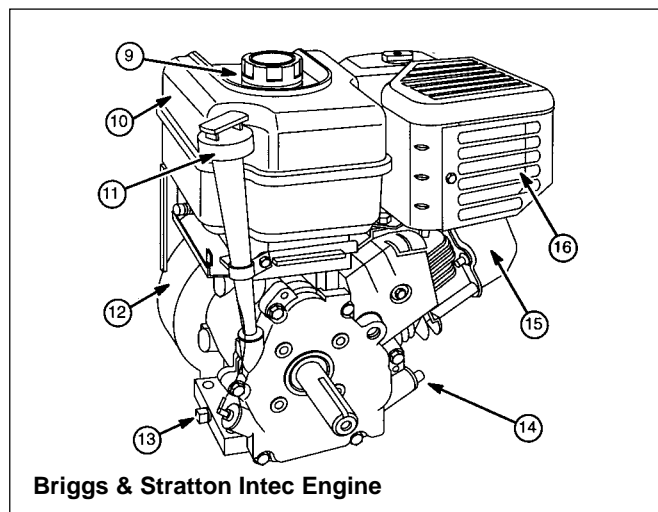
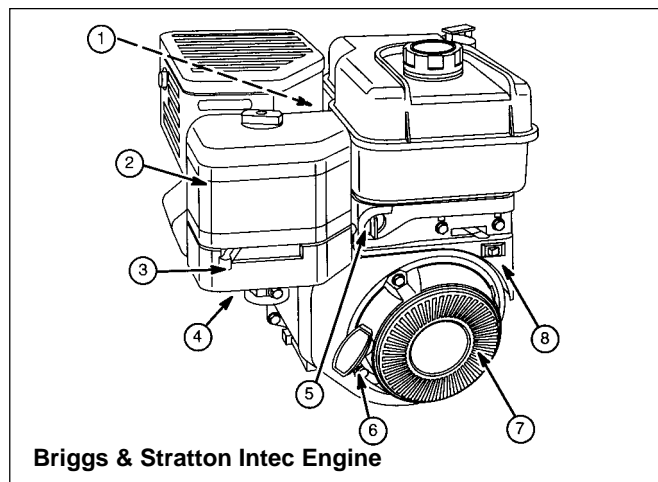

Adjustments

WHEEL LOCKOUTS (7016RT)

Place wheels in tilling position.

1. Pull knob in center of wheel out, away from machine.
2. Rotate knob and lockout to align with slot on axle, release knob. Rotate wheel to align slot in wheel hub with lockout.
3. Wheel and axle should be firmly locked together before tilling.
4. Repeat for other wheel.

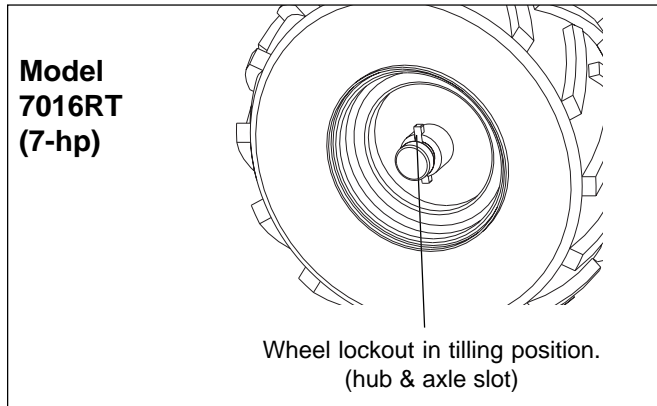

NOTE: Always have both wheel lockouts in or out. Do not operate tiller with only one wheel locked.

To place wheels in free-wheel position.

1. Pull knob in center of wheel out, away from machine.
2. Rotate knob and lockout to align lockout with detent in end of axle. Release knob.
3. Wheel should turn freely on axle.

WHEEL LOCKPINS (6016RT)

Place wheels in tilling position.

1. Remove lockpin. Align hole in axle with hole in wheel hub.
2. Insert lockpin through holes, fold lockpin ring to secure pin to axle.
3. Wheel and axle should be firmly locked together before tilling.
4. Repeat for other wheel.

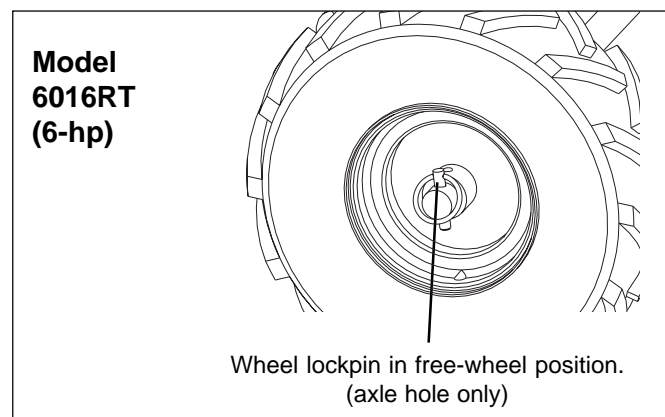

NOTE: Always have both wheel lockouts in or out. Do not operate tiller with only one wheel locked.

To place wheels in free-wheel position.

1. Remove lockpin. Slide wheel inward toward machine.
2. Insert pin in axle only.
3. Wheel should turn freely on axle.

WARNING

Never start engine or operate tiller with wheels in free-wheel position. The free-wheel position is for transporting the tiller long distances over level ground--do not attempt to move the tiller up or down steep grades in the free-wheel position.

HANDLEBAR ADJUSTMENTS

Height Adjustment

The ideal height of the handlebar varies with operator height and the depth of tilling.

To adjust handlebar height:

1. Remove bolt from lower crossbar of handlebar and pivot handlebar height adjuster.
2. Align handlebar to desired hole on the height adjuster.
3. Install bolt and retighten.

Swivel Adjustment

Handlebar swivels 20° left or right for operator comfort.

To swivel handlebar:

1. Pull detent pin out of hole in pivot lock bar.
2. Rotate handlebar 20° left or right.
3. Insert detent pin in hole.

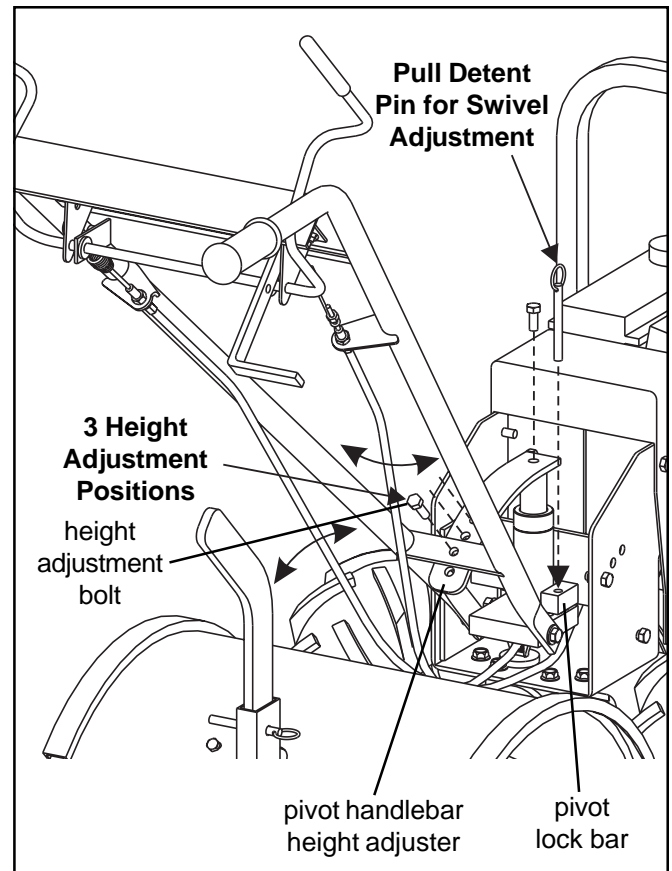

Adjustments

DEPTH REGULATOR LEVER

Tilling depth is controlled by the height of the depth regulator lever.

To adjust tilling depth.

1. Remove detent pin.
2. Raise the depth regulator lever to position tines at chosen tilling depth.
3. Align hole in depth regulator lever with hole in depth regulator bracket and replace detent pin.

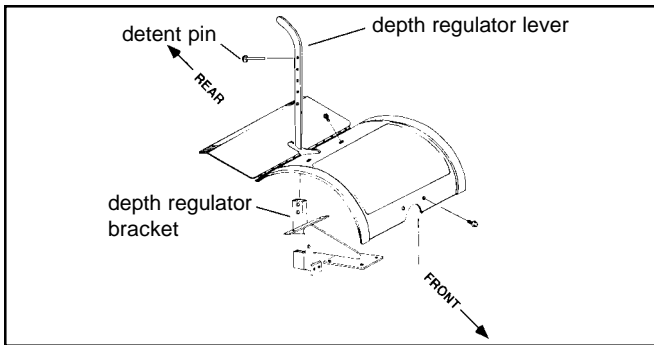

Depth Regulator Lever Down = Shallower tilling. Place the detent pin in the top hole of the depth regulator lever for shallowest tilling.

Depth Regulator Lever Up = Deeper tilling. Place the detent pin in the bottom hole of the depth regulator lever for deepest tilling.

WARNING

Always set the depth regulator lever in the transport position before starting engine, that is, place the detent pin in the highest hole of the depth regulator lever.

WARNING

Do not adjust tilling depth unless drive safety control levers are released to neutral position.

BELT TENSION ADJUSTMENT

Proper belt tension is critical to good performance. After 1/2 hour of operation, all cables may have to be adjusted due to initial stretch. Thereafter, check tension after every 2 hours of operation.

To increase belt tension:

1. Loosen upper jam nut. Turn nut up cable in 1/8" increments.
2. Tighten lower jam nut.
3. Check adjustment.

This procedure can be repeated until conduit adjustment bolts have no more adjustment left. If no more adjustment can be made, belt may have to be replaced.

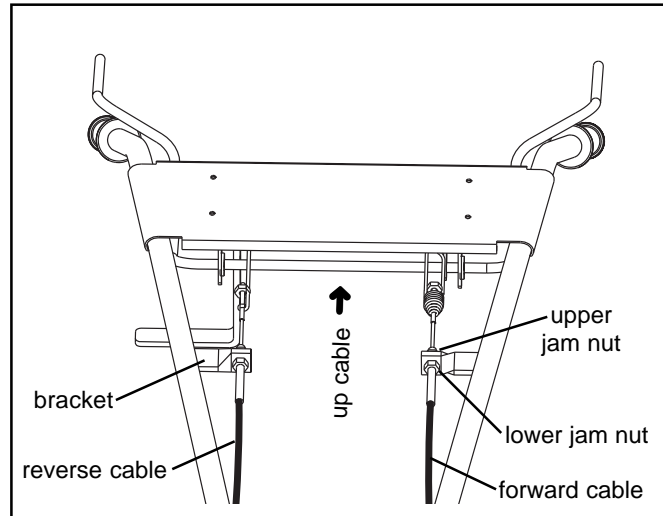

PRE-START INSPECTION

1. Make sure all safety guards are in place and all nuts and bolts are secure.
2. Check oil level in engine crankcase. See your engine manual for procedure and specifications.
3. Inspect air cleaner for cleanliness. See your engine manual for procedure.
4. Check the fuel supply. Fill the fuel tank no closer than 1 inch from top of tank to provide space for expansion. See your engine manual for fuel recommendations.
5. Be sure spark plug wire is attached and spark plug is tightened securely.
6. Check position of wheels and wheel lockouts.
7. Check depth regulator lever position.



CAUTION

Please do not start your tiller until you have read the Manual that came with your engine, and the sections in this manual titled Controls, Adjustments and Safety. If you have read these, follow the steps below to start your tiller. Always perform this pre-start checklist before starting the engine.



WARNING

Gasoline is highly flammable and must be handled with care. Never fill the tank when the engine is hot or running. Always move outdoors to fill the tank.



WARNING

Wheels must always be locked in the TILLING position when engine is running. Do not operate the tiller with the wheel lockouts unlocked. Always set the wheels in tilling position before starting engine.



WARNING

Always put the depth regulator lever in the transport position before starting engine. Tines should clear the ground.



ENGINE IS SHIPPED FROM FACTORY WITHOUT OIL. YOU MUST ADD ENGINE OIL BEFORE STARTING ENGINE.

START-UP

The controls required to start and run the rototiller are located on the engine and are marked "Choke" and "Throttle".

A more detailed description of engine operation and all related precautions and procedures can be found in the engine manufacturer's manual that accompanies each tiller.

Cold Starts

1. Move choke lever to full choke position.
2. Move throttle lever to "start".
3. Pull starting rope out slowly one time and allow to return normally.
4. Pull starting rope out rapidly, and allow rope to return normally.
5. When engine starts, gradually move choke lever to "no choke" position and increase throttle speed.

Restarting A Warm Engine

Restarting an engine that is already warm from previous running does not normally require use of the choke.

1. Move throttle lever to "start" position.
2. Pull starting rope out rapidly until engine starts. Allow rope to return normally.
3. Adjust throttle speed to "high" for best tiller action.

Idle Speed

Use the "low" position on the throttle lever to reduce stress on the engine when tilling is not being performed. Lowering the engine speed to "idle" the engine will help extend the life of the motor, as well as conserve fuel and reduce the noise level of the equipment.

Operating Speed

For normal tilling, set the throttle lever to "fast".



DANGER

Always keep hands and feet clear of rotating machine parts.

Operation

 **WARNING**

Temperature of muffler and near by areas may exceed 150° F. Avoid these areas.

 **WARNING**

Do not move choke control to **CHOKE** to stop engine. Backfire or engine damage may occur.

SHUTTING DOWN

 **DANGER**

Engine and surrounding parts become extremely hot during normal use, and will cause serious burn injuries if touched before the engine has cooled.

Allow engine to cool completely before touching these hot surfaces.

 **WARNING**

To stop the engine at any time, move throttle control to the off position. To stop wheels and tines at any time, release drive safety control levers to neutral position.

TILLING

1. Adjust the depth regulator lever to desired tilling depth.

NOTE: Raise depth regulator lever up one hole at a time, testing tiller operation after each raise. Raising depth regulator lever too high can result in loss of control of tiller!

2. Move the throttle control to *fast*.
3. Place the tiller in *forward* by pushing down on the drive safety control levers--this will engage the wheels and tines.

NOTE: You can slow the tiller's forward advance at any time by putting slight downward pressure on the handlebars, or you can stop the tiller by releasing the drive safety control levers to the neutral position.

 **WARNING**

To stop wheels and tines at any time, release drive safety control levers to neutral position.

 **WARNING**

Always release drive safety control levers to neutral position before adjusting the depth regulator lever.

IMPORTANT

Practice operating the controls and tiller with tines out of ground before beginning to till. It is important that you know how to use the tiller properly, how to keep control at all times, how to stop the tines and wheels from turning, and how to stop the engine if necessary. If you do not know how to do these things, read the Controls, Adjustments and Safety sections before proceeding.

TILLING TIPS

The key to successful tilling is to begin with a shallow cut on the first pass, and then work an inch or two deeper on each successive pass.

- ★ Tilling depth will vary with ground conditions.
- ★ When beginning to till in unbroken ground or in extremely hard soil, set the detent pin in the highest hole of the drag stake (follow instructions under Tilling on previous page). This will allow for shallow tilling. With the drag stake in this position, make several light passes over the area to be tilled. Reset for deeper depths with successive passes.
- ★ If tiller jumps or skids uncontrollably, lower the drag stake by placing the detent pin in a higher hole. This will allow for shallower tilling. Hold firmly to the handlebars to control sudden lurches.
- ★ If weeds, tall grasses, vines, or other materials clog or jam the tines, reverse the tiller to unwind vegetation.

*Immediately release the drive control levers if the tines jam or you strike a foreign object. With drive control levers in neutral, push throttle control to **stop** position to stop the engine. Disengage the spark plug wire. When tines have stopped, remove foreign objects and check for damage.*

CULTIVATING TIPS

If you plan to use your tiller for cultivating:

- ★ Plant rows on 20" - 22" centers for ease of turning.
- ★ Set the drag stake with the detent pin in one of the higher holes. This will allow the shallow cultivation necessary to turn over weeds, and break up and aerate the soil.

WARNING

Extreme caution must be taken in selecting tilling depth. If you attempt to till too deeply for soil conditions, that is, with the drag stake in too high a position, loss of control could result.

WARNING

If removing material from the tines by hand, stop engine and remove spark plug wire first.

Normal Care

SCHEDULE

Your rototiller has been designed and produced by the industry's leading manufacturer of outdoor power equipment to provide you with years of reliable operation.

Keeping your tiller in top running condition will prolong its life, and help you obtain optimum performance whenever you wish to till your garden.

Please read this normal care schedule, and observe these recommended care operating intervals to extend the life of your unit.

<i>Maintenance Operation</i>	<i>Page</i>	<i>Before Each Use</i>	<i>50 hrs or Every Season</i>
<i>Check forward/reverse belt tension</i>	<i>15</i>	<i>X</i>	
<i>Change forward/reverse belt</i>	<i>16</i>		<i>X</i>
<i>Engine maintenance</i>	<i>17</i>	<i>X</i>	<i>X</i>
<i>Check or fill oil sump</i>	<i>17, EM</i>	<i>X</i>	
<i>Check tiller transmission grease</i>	<i>18</i>	<i>X</i>	
<i>Check tire pressure</i>	<i>18</i>	<i>X</i>	
<i>Lubrication</i>	<i>18</i>	<i>X</i>	
<i>Clean tine axle shaft</i>	<i>18</i>	<i>X</i>	
<i>Lubricate wheel axle shaft</i>	<i>19</i>		<i>X</i>
<i>Check throttle control adjustment</i>	<i>EM</i>		<i>1</i>

EM = See engine manual

- 1 Adjust throttle control after first 3 hours of operation or if engine is hard to start or run-on occurs.
- 2 Change oil after first 5-8 hours of use, then after every 50 hours or every season. Change oil every 25 hours when operating under heavy load or in high temperatures.

SERVICING THE ROTOTILLER

General

The following information will help you make the necessary checks and perform the procedures required to follow the normal care recommendations made for your rototiller unit.

If you prefer, your local authorized dealer can make these checks and perform the required procedures for you.

Check Forward Belt Tension

Forward belt tension may decrease over time. It must be adjusted within the first half hour of operation, and checked after every two hours of operation. Proper adjustment will assure long belt life. Too much or too little belt tension will cause premature belt failure. To check and adjust the forward belt tension:

1. Turn off engine. Engine must be cool.
2. Remove and secure spark plug wire from spark plug.
3. With drive safety control levers in neutral position, measure length of spring when compressed.
4. Pull down on drive safety control levers and remeasure length of spring when stretched out. Ideal length would be 1/4" longer.

Check Reverse Belt Tension

Reverse belt tension is not adjustable.

WARNING

To prevent accidental starting:

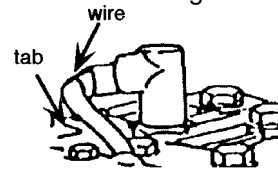

Engine must be turned off and cool, and spark plug wire must be removed and secured from spark plug before checking and adjusting engine or equipment.

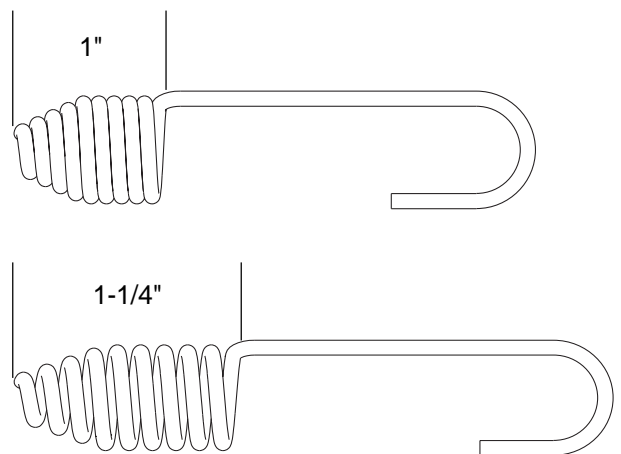

WARNING

Check forward belt tension regularly. Too much or too little tension will cause premature belt failure.

Normal Care

Change Forward/Reverse Belt

1. Turn off engine. Engine must be cool.
2. Remove spark plug wire and secure from spark plug.
3. Remove belt guard.

★ remove the forward belt from the forward engine pulley:

- gently pull the engine recoil rope to rotate the pulley.
- with the pulley turning, force the forward belt out of the V-groove.
- slide the belt free of the engine pulley.
- pull the forward belt down and out of the way.

★ remove the reverse belt from the reverse engine pulley:

- gently pull the engine recoil rope to rotate the pulley.
- with the pulley turning, force the reverse belt out of the V-groove.
- slide the belt free of engine pulleys and reverse belt guides.
- pull belt down and away from transmission pulley.

★ install new reverse belt:

- thread belt up from bottom.
- place belt around transmission pulley in groove.
- place belt under reverse belt guides.
- gently pull engine recoil rope while forcing the belt over the edge of the engine pulley into the V-groove.

★ install new forward belt:

- place forward belt in transmission pulley groove.
- gently pull the engine recoil rope to rotate the pulley while forcing the forward belt into the V-groove.

4. Replace belt guard.
5. Attach spark plug wire.

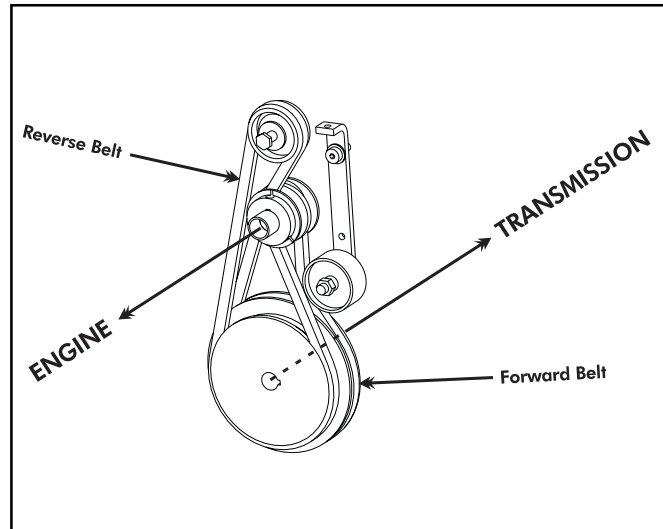

⚠ CAUTION

Do not operate tiller before reading the engine manual provided in the parts packet.

⚠ WARNING

Temperature of muffler and near by areas may exceed 150° F. Avoid these areas.

IMPORTANT

Engine can overheat and become damaged if debris blocks the cooling system or rotating screen.

IMPORTANT

Never run engine without complete air cleaner installed on engine.

IMPORTANT

Engine is shipped from factory without oil. You must add engine oil before starting engine.

Check or Fill Oil Sump

1. Add oil according to engine manual. **Do not overfill.** Use a clean, high quality detergent oil. Container must be marked A.P.I. Service SF - SJ. Use no special additives with recommended oils. **Do not mix oil with gasoline.** Oil level must be full. Check the oil level by removing oil fill plug. Oil level should be up to the bottom of the fill plug opening.
2. Always check oil level before starting engine. Refer to engine manual for capacity and type of oil to use.

Engine Maintenance

Refer to the engine manual included in your parts packet for information on engine maintenance. Your engine manual provides detailed information and a maintenance schedule for performing the following tasks:

1. Check oil level before each use or after every 8 hours of operation.
2. Change oil after first 5-8 hours of operation. Change oil while engine is warm. Refill with new oil of recommended grade.
4. Check spark plug yearly or every 100 hours of operation.
5. Service air cleaner.
6. Keep engine and parts clean.
7. Check engine and equipment often for loose nuts and bolts, keep these items tightened.

The diagrams illustrate the steps for checking and filling the oil sump. The top section shows the 'High Oil Fill' procedure, and the bottom section shows the 'Low Oil Fill' procedure. Each procedure includes four numbered steps with corresponding illustrations.

High Oil Fill (if equipped)

- [1] Place engine level and clean around oil fill area.
- [2] Remove dipstick and wipe clean with cloth. Replace and tighten dipstick. Remove and check oil level.
- [3] Pour oil slowly. Fill to FULL line on dipstick – recheck.
- [4] Replace and tighten dipstick.

Low Oil Fill

- [1] Place engine level and clean around oil fill area.
- [2] Remove oil fill cap.
- [3] Pour oil slowly. Fill to point of overflowing.
- [4] Replace and tighten oil fill cap.

Adapted from Briggs & Stratton Corporation, Form No. 274263-10/99.

Normal Care

Check Tiller Transmission Grease

IMPORTANT

TILLER TRANSMISSION IS SHIPPED FROM FACTORY WITH THE PROPER AMOUNT OF 00 LIQUID GREASE.

Check the grease level annually. To check the grease level:

1. Move tiller to level ground.
2. Remove grease level dipstick located between the handlebar mounts in the front transmission cover. Correct 00 grease level is indicated between the high and low levels on the dipstick.
3. Replace grease level dipstick in the filler hole.
4. Note that the front wheel transmission and rear tine transmission are one common reservoir. When you add to the front transmission, you must wait a short period of time for the 00 grease to flow rearward and equalize in both front and rear. The dipstick will read correctly on level ground for both gear units.

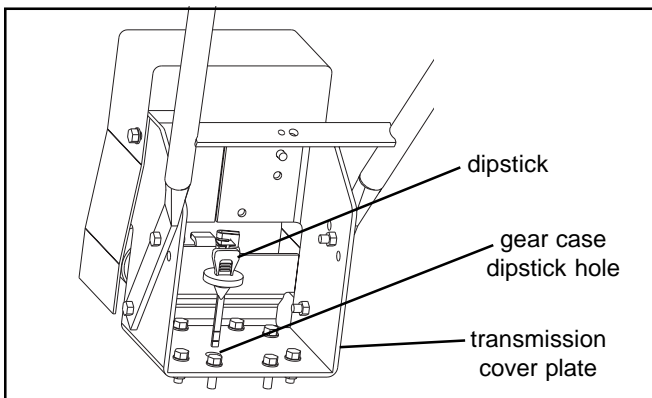

IMPORTANT

When replacing grease, the tiller transmission holds 18-22 ounces. DO NOT OVERFILL.

Check Tire Pressure

Recommended tire pressure is 20 PSI. If tires do not have equal pressure, tiller will pull to one side.

Lubrication

Proper lubrication of moving mechanical parts of your rototiller is a very important part of care and maintenance. You should oil the moving parts shown at 10 hour intervals using a 30 weight oil.

Clean Tine Axle Shaft

1. Turn off engine. Engine must be cool.
2. Remove spark plug wire and secure from spark plug.
3. Tip the tiller forward. Block the tiller in position so that it rests on the engine mount and the tines are exposed.
4. Remove all vegetation, string, wire, and other material that may have accumulated on the axle between the inside set of tines and the seal on the transmission housing.
5. Tip the tiller back to a level position.
6. Replace spark plug wire.

PREPARE FOR STORAGE

Follow the steps below to prepare your tiller for storage. Read your engine manual for detailed instructions on preparing the engine for storage.

1. Protect wheels and axles from rust:
 - Loosen locking bolt inside wheel. Slide wheel toward machine.
 - Coat the axles lightly with axle grease.
 - Move wheel back into position and snug locking bolt. Back off locking bolt 1/16 turn and lock jam nut.
2. Drain fuel system completely following engine manufacturer's instructions or add fuel stabilizer to prevent fuel from gumming up during extended storage period.
3. While engine is still warm, drain the oil from the engine. Refill with fresh oil of the recommended grade.
4. Clean external surfaces, engine and cooling fan.
5. Remove spark plug, pour one ounce of SAE 30 oil into spark plug hole.
6. Plug hole and pull starter cord slowly to distribute oil evenly in cylinder head area.
7. Reinstall spark plug.
8. Transport unit to a suitable storage location. If you have chosen to use a fuel stabilizer and have not drained the fuel system, follow all safety instructions and storage precautions in this manual to prevent the possibility of fire from the ignition of gasoline fumes. Remember, gasoline fumes can travel to distant sources of ignition and ignite, causing risk of explosion and fire.
9. If there is any possibility of unauthorized use or tampering, remove the spark plug and store it in a safe place before storing the rototiller unit away. Be sure to plug the spark plug hole to prevent foreign material from entering.

 **WARNING**

Do not store tiller in an unventilated area where fuel fumes may reach flame, sparks, pilot lights or an ignited object. Drain fuel outdoors away from any ignition sources. Use only approved fuel containers.

Troubleshooting and Repair

TROUBLESHOOTING GUIDE

While normal care and routine maintenance will extend the life of your rototiller, prolonged or constant use may eventually require that service be performed to allow it to continue operating properly. The troubleshooting guide below lists the most common problems, causes and remedies.

WARNING

Practice safety at all times. Engine must be turned off and allowed to cool, and spark plug wire must be disconnected and secured before attempting any maintenance or repair.

Failure to comply with this safety requirement can result in serious personal injury to you or bystanders.

PROBLEM	REMEDY/ACTION
Engine will not start	<ul style="list-style-type: none"> • Add gas to gas tank. • Connect spark plug wire to spark plug • Throttle must be positioned at choke for a cold start (see page 11 for instructions)
Engine runs rough, floods during operation	<ul style="list-style-type: none"> • Clean or replace air cleaner
Engine is hard to start	<ul style="list-style-type: none"> • Drain old fuel and replace with fresh. Use gas stabilizer at end of season • Make sure spark plug wire is securely attached to spark plug • Drive safety control levers must be released to <i>neutral</i> to start the engine
Engine misses or lacks power	<ul style="list-style-type: none"> • Raise the tines for shallower tilling by lowering the depth regulator lever, see page 10 • Remove and clean fuel tank • Clean or replace air cleaner • Improper carburetor adjustment, take to authorized Briggs & Stratton service center • Replace spark plug and adjust gap • Drain and refill gas tank and carburetor
Engine will not stop when throttle control is positioned at stop	<ul style="list-style-type: none"> • See engine manual to check and adjust throttle linkage
Tiller moves forward during starting	<ul style="list-style-type: none"> • Drive safety control levers must be released to <i>neutral</i> to start the engine
Tiller is difficult to control when tilling (machine jumps or lurches forward)	<ul style="list-style-type: none"> • Lock wheels in tilling position, see page 8 • Raise the tines for shallower tilling by lowering the depth regulator lever, see page 10
Tines turn, wheels do not turn	<ul style="list-style-type: none"> • Lock wheels in tilling position, see page 8 • Internal transmission failure, see your dealer
Tines turn, wheels turn, tiller does not move	<ul style="list-style-type: none"> • Lower the tines for deeper tilling by raising the depth regulator lever, see page 10

Troubleshooting and Repair

PROBLEM	REMEDY/ACTION
<p>Belts squeal in neutral and/or reverse</p>	<ul style="list-style-type: none"> • Adjust forward belt guide: <ul style="list-style-type: none"> - turn engine off and allow muffler to cool - disconnect spark plug wire and secure from spark plug - remove belt guard - pull down on drive safety control levers - manually bend forward belt guide so there is 1/16 inch or less clearance between belt guide and belt - replace belt guard and spark plug wire
<p>Belts squeal in forward operation</p>	<ul style="list-style-type: none"> • Adjust tabs on the reverse belt guide <ul style="list-style-type: none"> - turn engine off and allow muffler to cool - disconnect spark plug wire and secure from spark plug - release drive safety control levers to <i>neutral</i> - remove belt guard - adjust tabs of reverse belt guide: <ul style="list-style-type: none"> while drive safety control levers are released, bend metal tabs on reverse belt guide to 1/64 inch or less clearance from reverse belt - replace belt guard and spark plug wire
<p>Excessive heat build up in transmission/tine area during tilling</p>	<ul style="list-style-type: none"> • Remove vegetation by following instructions in Clean Tine Axle Shaft on page 18 of Maintenance & Storage section. FOLLOW ALL SAFETY INSTRUCTIONS • Check transmission fluid and fill if needed by following instructions on page 18

Specifications

FEATURES

- ☆ 7-HP Briggs & Stratton Engine (7016RT)
- ☆ 6-HP Briggs & Stratton Engine (6016RT)
- ☆ Tractor Type Pneumatic Tires
- ☆ All Gear Drive Transmission
- ☆ Handlebar Height Adjustment
- ☆ Forward/Reverse Control
- ☆ Functional Depth Regulator System
- ☆ Wheel Lockout Control (7016RT)
- ☆ Wheel Lockpins (6016RT)
- ☆ Drive Safety Control Levers
- ☆ Self Cleaning Bolo Tines (7016RT)
- ☆ Double Bolo Tines (6016RT)
- ☆ Bumper Guard (7016RT)
- ☆ Hiller-Furrower Attachment (7016RT)

Technical Manuals

Additional copies of this manual, as well as a fully illustrated parts manual for your unit are also available. The parts manual shows all of the assemblies and individual parts as exploded views which show the relationship of the parts and how they go together. Important assembly notes and special torque values are included in the illustrations. Standard hardware and torque specification charts are also included.

To order copies of the manuals applicable to your model, contact the Simplicity Customer Publications Department at 414-284-8519.

Have the information on the form at the right available when phoning in your request.

Please allow 3 to 4 weeks for delivery.

Model: _____

M/N (Mfg. No.): _____

S/N (Serial #): _____

Your Name: _____

Address: _____

City, State, Zip: _____

Visa/Mastercard No.: _____

Card Expiration Date: _____





MANUFACTURING, INC.
500 N Spring Street / PO Box 997
Port Washington, WI 53074-0997

www.SimplicityMfg.com



Snapper Inc.
535 Macon Street
McDonough, GA 30253

www.snapper.com

© Copyright 2005 Simplicity Manufacturing, Inc.
All Rights Reserved. Printed in USA.

